



Models 6760, and 6767 Shown

**FEATURES**

**Superior Design**

- Triplex plunger design provides smoother liquid flow.
- Special ported inlet manifold permits an external flush liquid providing cooling for hi-temp liquids and lubrication for low lubricity liquids.
- V-Packings are completely lubricated and cooled by the liquid being pumped.
- Inlet and discharge valve assemblies interchange for easier maintenance.
- Oil bath crankcase assures optimum lubrication.
- Close tolerance concentricity of the ceramic plunger maximizes seal life.

**Quality Materials**

- Precision design 316 stainless steel valves and seats are hardened and polished for ultimate seating and extended valve life.
- Brass, cast Nickel Aluminum Bronze, 316 Stainless Steel or Duplex SS manifolds for strength and corrosion resistance.
- Special concentric, high-density, polished, solid ceramic plungers provide a true wear surface and extend seal life.
- Specially formulated, CAT PUMP exclusive, V-Packings offer unmatched performance and seal life.
- Die cast aluminum crankcase provides high strength, minimum weight and precision tolerance control.
- Chrome-moly crankshaft gives unmatched strength and surface hardness.
- Oversized crankshaft bearings with greater loading capacity mean longer bearing life.

**Easy Maintenance**

- Wet-end is easily serviced without entering crankcase, requiring less time and effort.
- Valve assemblies are accessible without disturbing piping, for quick service.
- Preset packings mean no packing gland adjustment is necessary, reducing maintenance costs.

**⚠ WARNING**

All systems require both a primary pressure regulating device (i.e., regulator, unloader) and a secondary pressure safety relief device (i.e., pop-off valve, safety valve). Failure to install such relief devices could result in personal injury or damage to the pump or to system components. CAT PUMPS does not assume any liability or responsibility for the operation of a customer's high pressure system.

**60 Frame Plunger Pumps**

Standard Brass Model

**6760**

Stainless Steel Model

**6761**

Duplex SS Model

**6762**

Nickel Aluminum Bronze Model

**6767**

NAB Flushed Model

**6767C**

**SPECIFICATIONS**

	U.S. Measure	Metric Measure
Flow .....	60 GPM	(227 L/M)
Pressure Range.		
.....100 to 1200 PSI	(7 to 85 BAR)	
Inlet Pressure Range.		
.Flooded to 50 PSI	(Flooded to 3.5 BAR)	
RPM .....	520 RPM	(520 RPM)
Bore.....	2.165"	(55 mm)
Stroke.....	2.579"	(65.5 mm)
Crankcase Capacity.....	10 Qts.	(9.46 L)
Max. Liquid Temperature.....	140°F	(60°C)
Above 130°F call CAT PUMPS for inlet conditions and elastomer recommendations.		
Inlet Ports (2).		
.....2" NPTF	(2" NPTF)	
Flushing Ports (2) (6767C) .		
.....1/4" NPTF	(1/4" NPTF)	
Discharge Ports (2).		
.....1-1/4" NPTF	(1-1/4" NPTF)	

**ELECTRIC HORSEPOWER REQUIREMENTS**

FLOW		PRESSURE				RPM
U.S. GPM	L/M	PSI 900	PSI 1000	PSI 1200	PSI 2000	
60	227	BAR 60	BAR 70	BAR 85	BAR 140	520
50	189	37.1	41.2	49.4	N/A	433
		30.9	34.3	41.2	N/A	

DETERMINING THE PUMP R.P.M.	<u>Rated G.P.M.</u>	=	<u>"Desired" G.P.M.</u>
DETERMINING THE REQUIRED H.P.	<u>GPM x PSI</u>	=	<u>"Desired" R.P.M.</u>
DETERMINING MOTOR PULLEY SIZE	<u>1460</u>	=	<u>Electric Brake H. P. Required</u>
	<u>Motor Pulley O.D.</u>	=	<u>Pump Pulley O.D.</u>
	<u>Pump R.P.M.</u>	=	<u>Motor R.P.M.</u>

See complete Drive Packages [Incls: Pulleys, Belts, Hubs, Key] Tech Bulletin 003.  
Refer to pump Service Manual for repair procedure, additional technical information and pump warranty.

# PARTS LIST

ITEM	PART NUMBER				DESCRIPTION	QTY
	6760 MATL	6761 MATL	6762 MATL	6767 MATL		
2	43048 STL	43048 STL	43048 STL	43048 STL	Key (M14x9x90)	1
5	126532 STCP R	89728 S	89728 S	89728 S	Screw, HH (M10 x 40)	8
6	12503 STZP	15847 S	15847 S	15847 S	Lockwasher (M10)	8
	126231 STCP R	—	—	—	Lockwasher (M10)	8
7	126574 STCP R	19934 S	19934 S	19934 S	Washer, Flat (M10)	8
8	29443 AL	29443 AL	29443 AL	29443 AL	Cover, Bearing, Outer	2
10	29444 NBR	29444 NBR	29444 NBR	29444 NBR	O-Ring, Bearing Cover - 70D	2
11	11443 NBR	11443 NBR	11443 NBR	11443 NBR	Seal, Oil, Crankshaft - 70D	2
12	43642 S	43642 S	43642 S	43642 S	Washer, Shim (M120 x 0.3)	0-2
	126594 STCP R	126594 STCP R	126594 STCP R	126594 STCP R	Washer, Shim (M120 x 0.3)	0-2
13	126595 STCP R	126595 STCP R	126595 STCP R	126595 STCP R	Washer, Shim (M120 x 0.5)	0-2
15	29441 STL	29441 STL	29441 STL	29441 STL	Bearing, Roller	2
16	29442 STL	29442 STL	29442 STL	29442 STL	Cover, Bearing, Inner	2
17	29444 NBR	29444 NBR	29444 NBR	29444 NBR	O-Ring, Bearing Cover - 70D	2
20	126612 BBHS	126612 BBHS	126612 BBHS	126612 BBHS	Rod, Connecting (Incls: 21, 22)	3
21	126560 STCP R	126560 STCP R	126560 STCP R	126560 STCP R	Washer, Locking	3
22	126593 STCP R	126593 STCP R	126593 STCP R	126593 STCP R	Washer, Shim (M10.5 x 1.5)	6
25	29440 FCM	29440 FCM	29440 FCM	29440 FCM	Crankshaft, Dual End	1
31	828710 —	828710 —	828710 —	828710 —	Protector, Oil Cap w/Foam Gasket	1
32	43211 ABS	43211 ABS	43211 ABS	43211 ABS	Cap, Oil Filler	1
33	14177 NBR	14177 NBR	14177 NBR	14177 NBR	O-Ring, Oil Filler Cap - 70D	1
34	126743 STCP R	126743 STCP R	126743 STCP R	126743 STCP R	Bolt, Eye (M12) (For Lifting Pump Only)	1
38	11338 NBR	11338 NBR	11338 NBR	11338 NBR	O-Ring, Dip Stick - 70D	1
39	27769 ABS	27769 ABS	27769 ABS	27769 ABS	Stick, Dip	1
40	80288 STZP	89627 S	89627 S	89627 S	Screw, HH (M10 x 30)	8
	126531 STCP R	—	—	—	Screw, HH (M10 x 30)	8
41	12503 STZP	15847 S	15847 S	15847 S	Lockwasher (M10)	8
	126231 STCP R	—	—	—	Lockwasher (M10)	8
42	126574 STCP R	19934 S	19934 S	19934 S	Washer, Flat (M10)	8
48	25625 STCP	25625 STCP	25625 STCP	25625 STCP	Plug, Drain (1/4 x 19BSP)	1
49	23170 NBR	23170 NBR	23170 NBR	23170 NBR	O-Ring, Drain Plug - 70D	1
50	29438 AL	29438 AL	29438 AL	29438 AL	Cover, Rear	1
51	29439 NBR	29439 NBR	29439 NBR	29439 NBR	Gasket, Rear Cover	1
53	45303 AL	45303 AL	45303 AL	45303 AL	Crankcase w/Guide Pins (Incls: 34, 54)	1
54	43282 S	43282 S	43282 S	43282 S	Pin, Guide	2
55	126553 STCP R	89615 S	89615 S	89615 S	Stud (M16 x 70)	2
64	29481 CM	29481 CM	29481 CM	29481 CM	Pin, Crosshead	3
65	‡ 45384 SSZZ	45384 SSZZ	45384 SSZZ	45384 SSZZ	Rod, Plunger	3
69	126588 STCP R	126588 STCP R	126588 STCP R	126588 STCP R	Washer, Oil Seal	3
70	29454 NBR	29454 NBR	29454 NBR	29454 NBR	Seal, Oil - 80D	3
75	44752 NBR	44752 NBR	44752 NBR	44752 NBR	Slinger, Barrier - 85D	3
88	45677 SS	45677 SS	45677 SS	45677 SS	Washers, Keyhole (M14)	3
90	44749 CC	44749 CC	44749 CC	44749 CC	Plunger (M55 x 185)	3
95	89783 S	44748 SS	44748 SS	44748 SS	Stud, Plunger Retainer (M14 x 147)	3
96	20214 PTFE	20214 PTFE	20214 PTFE	20214 PTFE	Back-up-Ring, Plunger Retainer	3
97	17616 NBR	17616 NBR	17616 NBR	17616 NBR	O-Ring, Plunger Retainer - 80D	3
	11686 FPM	11686 FPM	11686 FPM	11686 FPM	O-Ring, Plunger Retainer - 80D	3
98	44751 SS	44751 SS	44751 SS	44751 SS	Gasket, Plunger Retainer	3
99	45276 S	44750 SS	48959 SSD	44750 SS	Retainer, Plunger (M14)	3
100	855000 PVDF	855000 PVDF	855000 PVDF	855000 PVDF	Retainer, Seal, 2-pc	3
101	44762 —	44762 —	44762 —	44762 —	Wick, Long Tab (M55 x 185)	3
106	44757 NBR	44757 NBR	44757 NBR	44757 NBR	Seal, LPS w/SS-Spg	3
	45882 FPM	45882 FPM	45882 FPM	45882 FPM	Seal, LPS w/SS-Spg	3
110	49457 NABC	45769 SS	48980 SSD	44754 NAB	Manifold, Inlet	1
	—	—	—	49305 NAB	Manifold, Inlet, Flushed (1/4" Flush Ports)	1
112	18175 NBR	18175 NBR	18175 NBR	18175 NBR	O-Ring, Spacer, Inner - 80D	3
	13266 FPM	13266 FPM	13266 FPM	13266 FPM	O-Ring, Spacer, Inner - 70D	3
114	44767 SS	44767 SS	48957 SSD	44767 SS	Spacer, Inlet Manifold	3
115	18175 NBR	18175 NBR	18175 NBR	18175 NBR	O-Ring, Spacer, Outer - 80D	3
	13266 FPM	13266 FPM	13266 FPM	13266 FPM	O-Ring, Spacer, Outer - 70D	3
116	126569 STCP R	19086 S	19086 S	19086 S	Lockwasher (M16)	4
117	126537 STCP R	89729 S	89729 S	89729 S	Screw, HH (M16 x 55)	4
126	48392 D	48392 D	48392 D	48392 D	Adapter, Female	3
	45771 SS	45771 SS	45771 SS	45771 SS	Adapter, Female	3
127	44764 STG*	44764 STG*	44764 STG*	44764 STG*	V-Packing	6
128	45772 SS	45772 SS	48962 SSD	45772 SS	Adapter, Male	3
141	44943 SS	44943 SS	44943 SS	44943 SS	Coil Spring, Spacer	24
142	48501 BB	45383 SS	48982 SSD	45383 SS	Spacer w/Coil Springs	3
155	18178 NBR	18178 NBR	18178 NBR	18178 NBR	O-Ring, Spacer - 80D	3
	13338 FPM	13338 FPM	13338 FPM	13338 FPM	O-Ring, Spacer - 70D	3
157	45321 SS	45321 SS	48961 SSD	45321 SS	Spacer, V-Packing	3
159	18178 NBR	18178 NBR	18178 NBR	18178 NBR	O-Ring, Spacer - 80D	3
	13338 FPM	13338 FPM	13338 FPM	13338 FPM	O-Ring, Spacer - 70D	3
160	44756 S	44756 S	44756 S	44756 S	Pin, Guide	2
163	18176 NBR	18176 NBR	18176 NBR	18176 NBR	O-Ring, Seat - 80D	6
	13278 FPM	13278 FPM	13278 FPM	13278 FPM	O-Ring, Seat	6
164	‡ 44772 SS	44772 SS	48964 SSD	44772 SS	Seat	6
166	‡ 44774 SS	44774 SS	48958 SSD	44774 SS	Valve	6
167	44773 SS	44773 SS	44773 SS	44773 SS	Spring	6
168	44775 PVDF	44775 PVDF	44775 PVDF	44775 PVDF	Retainer, Spring	6
170	‡ 44776 SS	44776 SS	48956 SSD	44776 SS	Washer, Retainer	6
171	44780 SS	44780 SS	44780 SS	44780 SS	Spring, Coil, Valve Plug	6
172	18177 NBR	18177 NBR	18177 NBR	18177 NBR	O-Ring, Valve Plug - 80D	6
	13279 FPM	13279 FPM	13279 FPM	13279 FPM	O-Ring, Valve Plug - 70D	6
174	49461 NABC	48572 SSL	48989 SSD	44778 NAB	Plug, Valve [3/00]	1
175	—	48573 S	48573 S	—	Screw, HSH (M16x35) [3/00]	24
185	49459 NABC	48489 SSL	48984 SSD	44769 NAB	Manifold, Discharge [3/00]	1

# EXPLODED VIEW

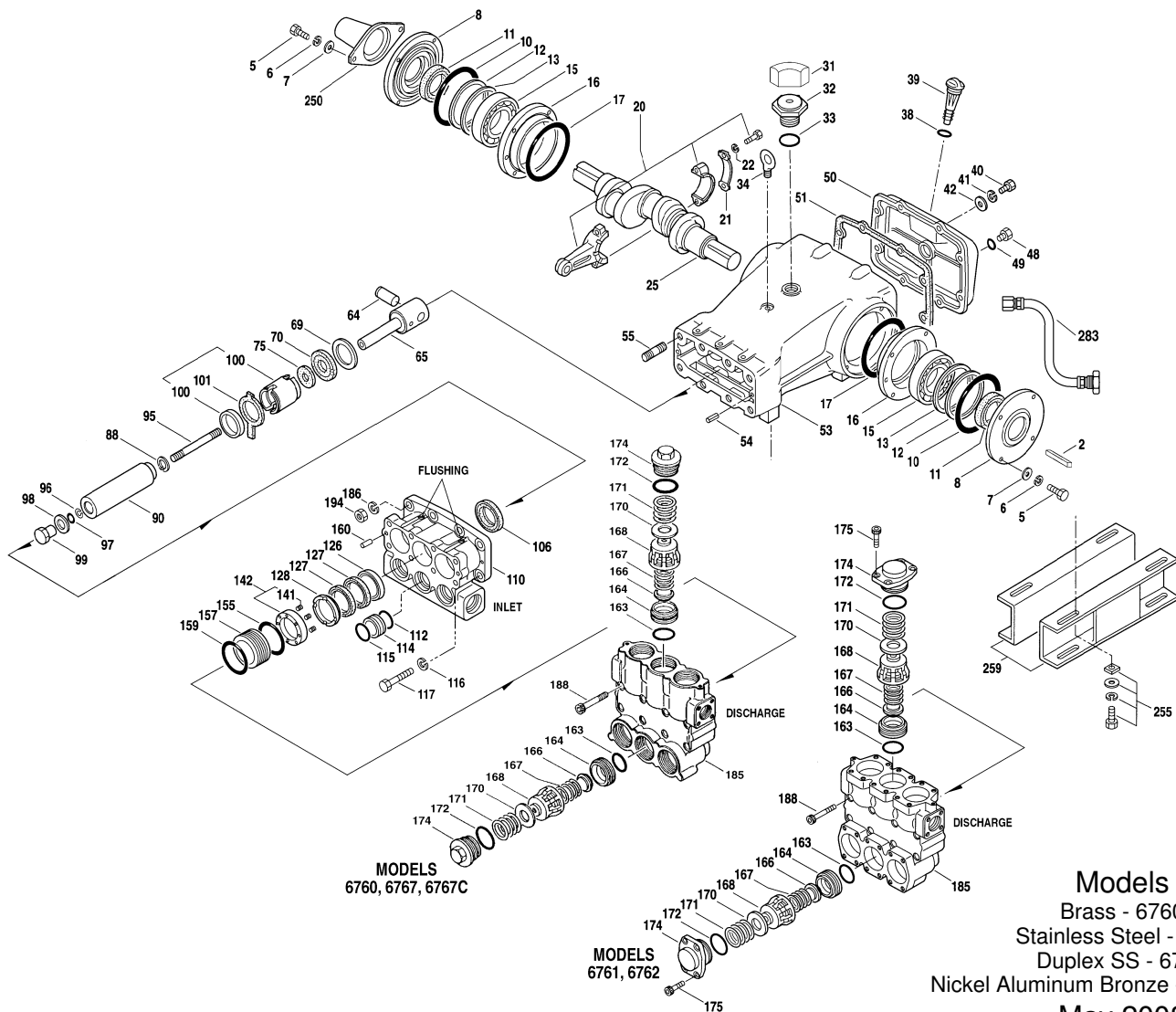

**Models**  
 Brass - 6760  
 Stainless Steel - 6761  
 Duplex SS - 6762  
 Nickel Aluminum Bronze - 6767, 6767C  
 May 2008

	<b>6760</b>	<b>MATL</b>	<b>6761</b>	<b>MATL</b>	<b>6762</b>	<b>MATL</b>	<b>6767</b>	<b>MATL</b>		
186	<b>126569</b>	<b>STCR R</b>	<b>19086</b>	<b>S</b>	<b>19086</b>	<b>S</b>	<b>19086</b>	<b>S</b>	Lockwasher (M16)	2
188	<b>126744</b>	<b>STCP R</b>	<b>89694</b>	<b>S</b>	<b>89694</b>	<b>S</b>	<b>89694</b>	<b>S</b>	Screw, HSH (M16 x 110)	8
194	<b>126525</b>	<b>STCP R</b>	<b>81291</b>	<b>S</b>	<b>81291</b>	<b>S</b>	<b>81291</b>	<b>S</b>	Nut, Hex (M16)	2
250	29445	AL	29445	AL	29445	AL	29445	AL	Protector, Shaft	1
255	33243	—	33243	—	33243	—	33243	—	Kit, Mount (Included w/Pump)	1
259	29477	STZP	29477	STZP	29477	STZP	29477	STZP	Rail (Included w/Pump) (Two per pump required)	2
275	990014	STL	990014	STL	990014	STL	990014	STL	Hub, 45mm (M14x9 Keyway) [See Drive Packages, Tech Bulletin 003]	1
279	30429	STZP	30429	STZP	30429	STZP	30429	STZP	Oiler (10 oz.) (Not Shown)	3
281	30969	—	30969	—	30969	—	30969	—	Oiler, Glass (10 oz.) (Not Shown)	3
282	10070	NBR	10070	NBR	10070	NBR	10070	NBR	Gasket, Oiler (Not Shown)	3
283	34314	—	34314	—	34314	—	34314	—	Kit, Oil Drain	1
290	6124	—	6124	—	6124	—	6124	—	Gasket, Liquid (3.0 oz.)	1
299	<b>816760</b>	<b>BBCP</b>	<b>816667</b>	<b>SSL</b>	<b>816865</b>	<b>SSD</b>	<b>814820</b>	<b>NAB</b>	Head, Complete	1
300	34091	NBR*	34091	NBR*	34091	NBR*	34091	NBR*	Kit, Seal (Incls: 97,106,112,115,127,155,159)	1
	34093	FPM*	34093	FPM*	—	—	34093	FPM*	Kit, Seal (Incls: 97,106,112,115,127,155,159)	1
310	‡ <b>34092</b>	<b>NBR</b>	<b>34092</b>	<b>NBR</b>	<b>39400</b>	<b>NBR</b>	<b>34092</b>	<b>NBR</b>	Kit, Valve (Incls: 163,164,166,167,168,170,172)	2
	31273	FPM	31273	FPM	—	—	31273	FPM	Kit, Valve (Incls: 163,164,166,167,168,170,172)	2
—	819010	F	819010	F	819010	F	819010	F	Assy, Crankcase, Cast Iron Conversion	1
—	88902	STZP	88902	STZP	88902	STZP	88902	STZP	Stud (M16x277) (For removing D.M., I.M.)	2
390	—	—	—	—	—	—	—	—	C.A.T. (Inlet pressure stabilizer for RO and boosted inlet applications)	1
391	—	—	—	—	—	—	—	—	Adapters (2 per C.A.T.) (See Data Sheet for complete selection)	2
—	6575	—	6575	—	—	—	6575	—	Plunger Pump Service DVD	1
—	6105	—	6105	—	6105	—	6105	—	Oil, Twin Pack (Two 2.5 Gal) ISO 68 Multi-viscosity Hydraulic (Fill to specified crankcase capacity prior to start-up)	1
—	—	—	6119	—	6119	—	—	—	Lubricant, Antiseize (1 oz.)	1

**Bold print part numbers are unique to a particular pump model. Italics are optional items. [ ]** Date of latest production change.

‡ Production parts 304SS, replacement parts are 316SS. R Components comply with RoHS Directive.

\*Review material codes for individual items (STG generally may be used as alternate).

See Tech Bulletins 003, 024, 036, 043, 052, 053, 054, 064, 074, 077, 082, 083, 084, 087, 095 and 105 for additional information.

**C.A.T. highly recommended for pressurized inlet, R.O. and industrial applications.**

MATERIAL CODES (Not Part of Part Number): ABS=ABS Plastic AL=Aluminum BB=Brass BBCP=Brass/Chrome Plated BBHS=Brass/High Strength  
 CC=Ceramic CM=Chrome-Moly D=Acetal F=Cast Iron FBB=Forged Brass FCM=Forged Chrome-moly FPM=Fluorocarbon NAB=Nickel Aluminum Bronze  
 NABC=Nickel Aluminum Bronze Chrome Plated NBR=Medium Nitrile (Buna-N) PTFE=Pure Polytetrafluoroethylene PVDF=Polyvinylidene Fluoride S=304SS SS=316SS  
 SSD=Duplex SS SSL=316SS/Low Carbon SSZZ=316SS/Zamak STCP=Steel/Chrome Plated STG=Special Blend PTFE White STL=Steel STZP=Steel/Zinc Plated

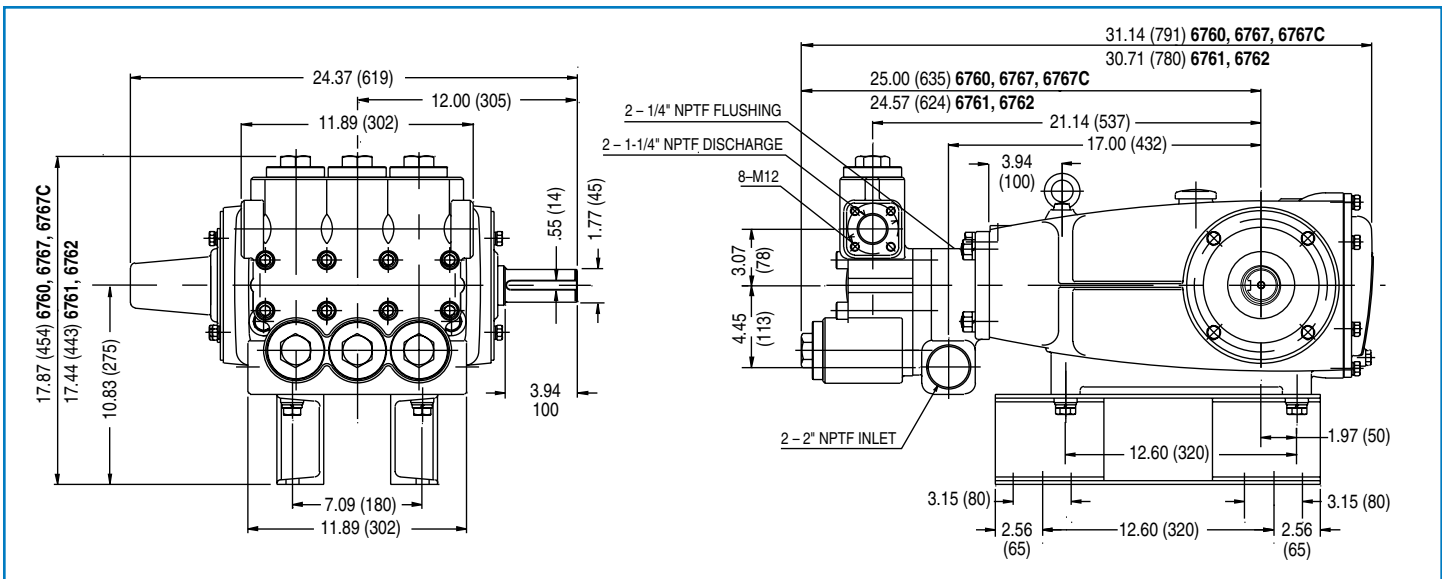

Models 6760, 6761, 6762, 6767, 6767C

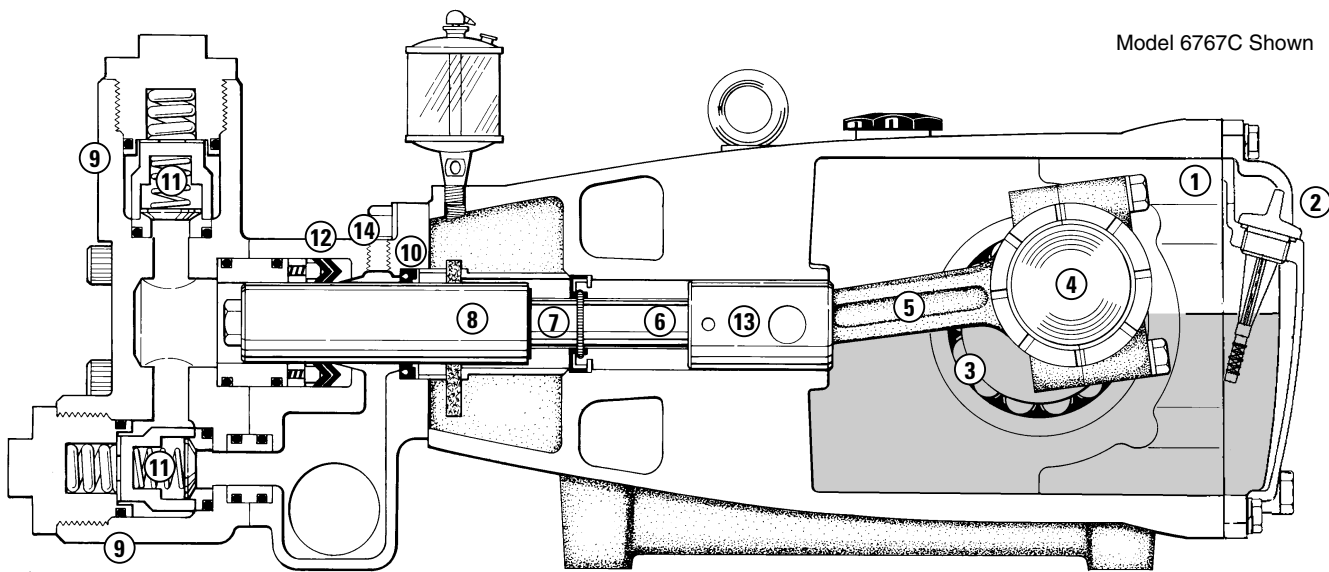

- 1 Die cast aluminum **crankcase** means high strength, lightweight, and excellent tolerance control.
- 2 **Dipstick** offers convenient top access for easy oil level check.
- 3 Oversized crankshaft **bearings** provide extended bearing life and pump performance.
- 4 Chrome-moly **crankshaft** provides unmatched strength and surface hardness for long life.
- 5 Matched oversized high strength **connecting rods** are noted for superior strength and bearing quality.
- 6 The **plunger rods** are high tensile strength stainless steel with Zamak crossheads.
- 7 The stainless steel **slinger** provides backup protection for the crankcase seal, keeping pumped liquids out of the crankcase.
- 8 Special concentric, high-density, polished, solid ceramic **plungers** provide a true wear surface and extend seal life.
- 9 **Manifolds** are a high tensile strength brass, nickel aluminum bronze, 316 stainless steel or Duplex SS for long term, continuous duty.
- 10 100% wet **seal** design adds to service life by allowing pumped liquids to cool and lubricate on both sides.
- 11 Stainless steel **valves, seats and springs** provide corrosion-resistance, ultimate seating and extended life.
- 12 Specially formulated, CAT PUMP exclusive, **V-Packings** offer unmatched performance and seal life.
- 13 **Crossheads** are 360° supported for uncompromising alignment.
- 14 Optional special **ported Flushed Inlet Manifold** permits external flush for lubricating and cooling seals when pumping liquids such as DI water, Hi-Temp or low lubricity.



LENNTECH

info@lennotech.com

Fax. +31-15-261.62.89

www.lennotech.com

Tel. +31-15-261.09.00